

## N-Channel Enhancement Mode Power MOSFET

### ■ Features

- Capable of 2.5V Gate Drive
- Low On-resistance
- Low Drive Current
- Surface Mount Package

### ■ General Description

The advanced power MOSFET provides the designer with the best combination of fast switching, ruggedized device design, ultra low on-resistance and cost-effectiveness.

### ■ Product Summary

BV <sub>DSS</sub> (V)	R <sub>DS(ON)</sub> (mΩ)	I <sub>D</sub> (A)
20	30	6

### ■ Pin Assignments

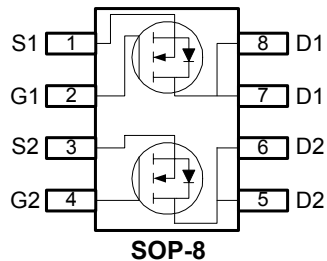

### ■ Pin Descriptions

Pin Name	Description
S1/2	Source
G1/2	Gate
D1/2	Drain

### ■ Ordering information

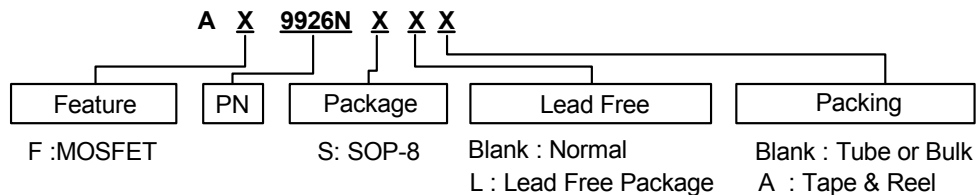



## N-Channel Enhancement Mode Power MOSFET

## ■ Absolute Maximum Ratings

Symbol	Parameter	Rating	Units
$V_{DS}$	Drain-Source Voltage	20	V
$V_{GS}$	Gate-Source Voltage	$\pm 12$	V
$I_D$	Continuous Drain Current (Note 1)	$T_A=25^\circ\text{C}$	6
		$T_A=70^\circ\text{C}$	4.8
$I_{DM}$	Pulsed Drain Current (Note 2)	26	A
$P_D$	Total Power Dissipation	2	W
	Linear Derating Factor	0.016	W/ $^\circ\text{C}$
$T_{STG}$	Storage Temperature Range	-55 to 150	$^\circ\text{C}$
$T_J$	Operating Junction Temperature Range	-55 to 150	$^\circ\text{C}$

## ■ Thermal Data

Symbol	Parameter	Maximum	Units
$R_{thj-amb}$	Thermal Resistance Junction-ambient (Note 1)	Max. 62.5	$^\circ\text{C}/\text{W}$

■ Electrical Characteristics at  $T_J=25^\circ\text{C}$  unless otherwise specified

Symbol	Parameter	Test Conditions	Min.	Typ.	Max.	Units
$BV_{DSS}$	Drain-Source Breakdown Voltage	$V_{GS}=0\text{V}$ , $I_D=250\mu\text{A}$	20	-	-	V
$\Delta BV_{DSS} / \Delta T_J$	Breakdown Voltage Temperature Coefficient	Reference to $25^\circ\text{C}$ , $I_D=1\text{mA}$	-	0.03	-	V/ $^\circ\text{C}$
$R_{DS(ON)}$	Static Drain-Source On-Resistance (Note 3)	$V_{GS}=4.5\text{V}$ , $I_D=6\text{A}$	-	-	30	m $\Omega$
		$V_{GS}=2.5\text{V}$ , $I_D=5.2\text{A}$	-	-	45	
$V_{GS(th)}$	Gate Threshold Voltage	$V_{DS}=V_{GS}$ , $I_D=250\mu\text{A}$	-	-	1.2	V
$g_{fs}$	Forward Transconductance	$V_{DS}=10\text{V}$ , $I_D=6\text{A}$	-	20	-	S
$I_{DSS}$	Drain-Source Leakage Current ( $T_J=25^\circ\text{C}$ )	$V_{DS}=20\text{V}$ , $V_{GS}=0\text{V}$	-	-	25	$\mu\text{A}$
	Drain-Source Leakage Current ( $T_J=70^\circ\text{C}$ )	$V_{DS}=20\text{V}$ , $V_{GS}=0\text{V}$	-	-	250	
$I_{GSS}$	Gate-Source Forward Leakage	$V_{GS}=12\text{V}$	-	-	100	nA
	Gate-Source Reverse Leakage	$V_{GS}=-12\text{V}$	-	-	-100	
$Q_g$	Total Gate Charge (Note 3)	$I_D=6\text{A}$ ,	-	23	35	nC
$Q_{gs}$	Gate-Source Charge	$V_{DS}=20\text{V}$ ,	-	4.5	7	
$Q_{gd}$	Gate-Drain ("Miller") Charge	$V_{GS}=5\text{V}$	-	7	11	
$t_{d(on)}$	Turn-On Delay Time (Note 3)	$V_{DS}=10\text{V}$ ,	-	30	60	ns
$t_r$	Rise Time	$I_D=1\text{A}$ ,	-	70	140	
$t_{d(off)}$	Turn-Off Delay Time	$R_G=6\Omega$ , $V_{GS}=5\text{V}$	-	40	80	
$t_f$	Fall-Time	$R_D=10\Omega$	-	65	130	
$C_{iss}$	Input Capacitance	$V_{GS}=0\text{V}$ ,	-	1035	-	pF
$C_{oss}$	Output Capacitance	$V_{DS}=20\text{V}$ ,	-	320	-	
$C_{rss}$	Reverse Transfer Capacitance	$f=1.0\text{MHz}$	-	150	-	

## ■ Source-Drain Diode

Symbol	Parameter	Test Conditions	Min.	Typ.	Max.	Unit
$I_S$	Continuous Source Current (Body Diode)	$V_D=V_G=0\text{V}$ , $V_S=1.3\text{V}$	-	-	1.54	V
$V_{SD}$	Forward On Voltage (Note 3)	$T_J=25^\circ\text{C}$ , $I_S=1.7\text{A}$ , $V_{GS}=0\text{V}$	-	0.78	1.2	V

**Note 1:** Surface mounted on 1 in<sup>2</sup> copper pad of FR4 board, 135 $^\circ\text{C}/\text{W}$  when mounted on Min. copper pad.

**Note 2:** Pulse width limited by Max. junction temperature.

**Note 3:** Pulse width  $\leq 300\mu\text{s}$ , duty cycle  $\leq 2\%$ .

## N-Channel Enhancement Mode Power MOSFET

### Typical Performance Characteristics

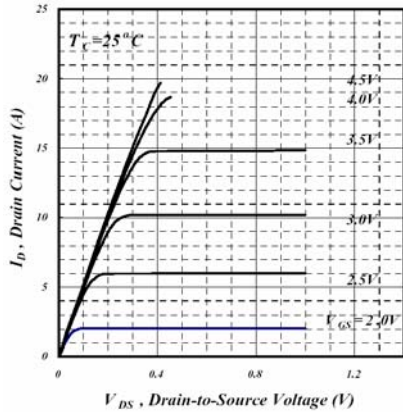

Fig 1. Typical Output Characteristics

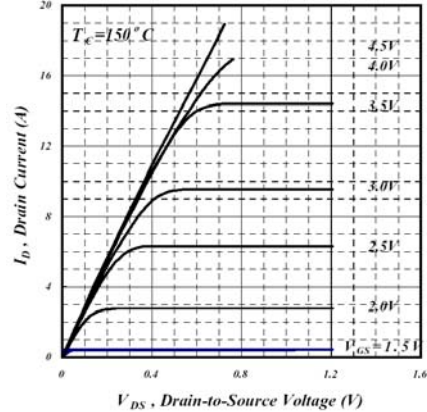

Fig 2. Typical Output Characteristics

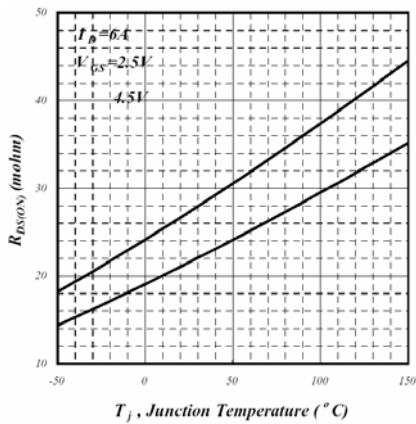

Fig 3.  $R_{DS(on)}$  v.s. Junction Temperature

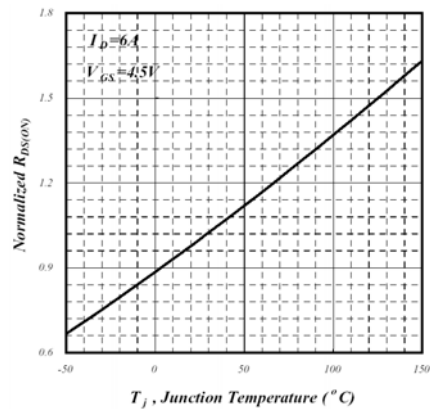

Fig 4. Normalized On-Resistance v.s. Junction Temperature

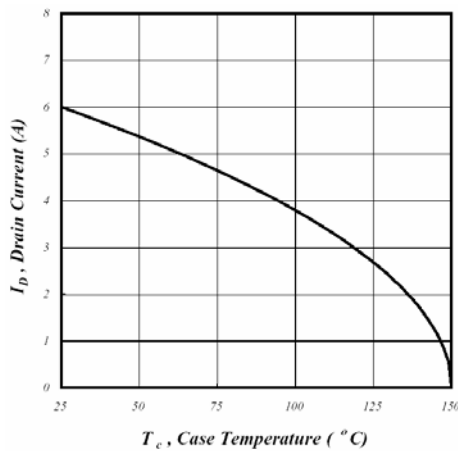

Fig 5. Maximum Drain Current v.s. Case Temperature

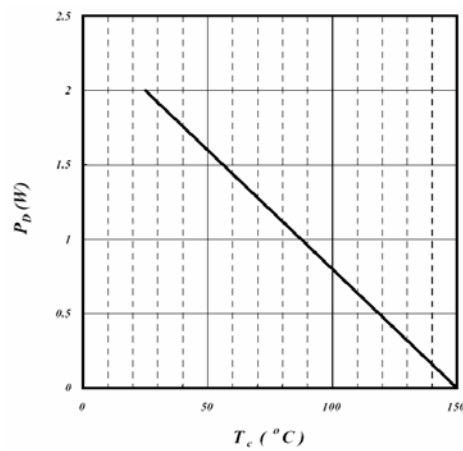

Fig 6. Typical Power Dissipation

## N-Channel Enhancement Mode Power MOSFET

### ■ Typical Performance Characteristics (Continued)

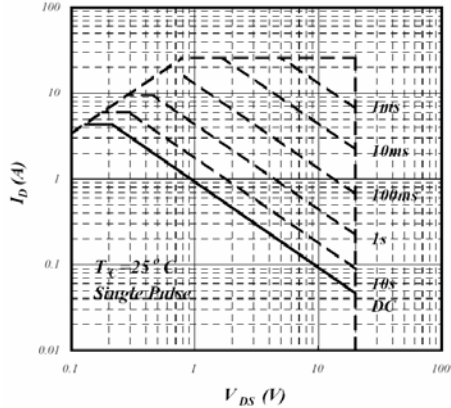

Fig 7. Maximum Safe Operating Area

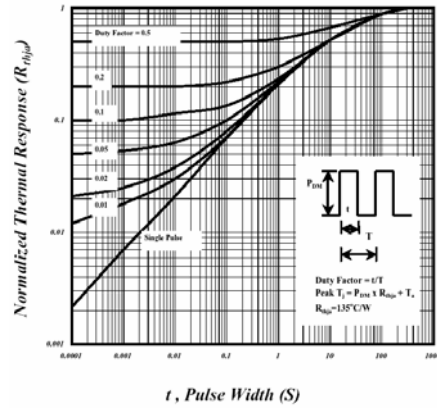

Fig 8. Effective Transient Thermal Impedance

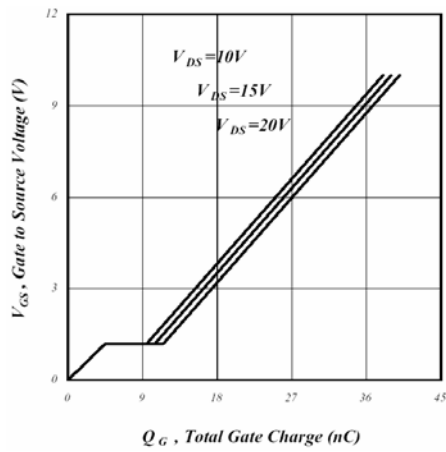

Fig 9. Typical Gate Charge v.s.  $V_{GS}$

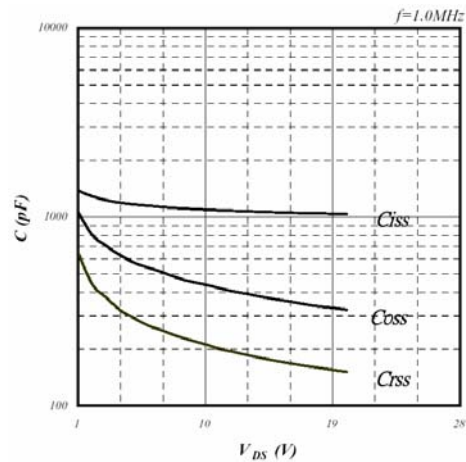

Fig 10. Typical Capacitance v.s.  $V_{DS}$

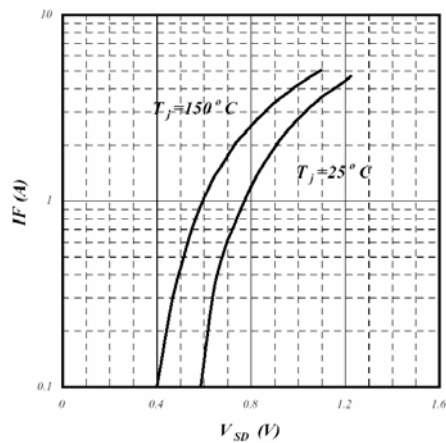

Fig 11. Forward Characteristic of Reverse Diode

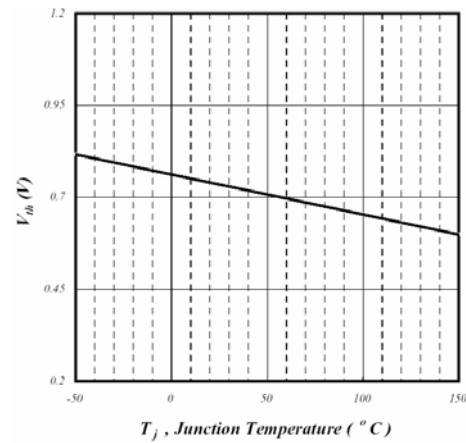

Fig 12. Gate Threshold Voltage v.s. Junction Temperature

## N-Channel Enhancement Mode Power MOSFET

### ■ Typical Performance Characteristics (Continued)

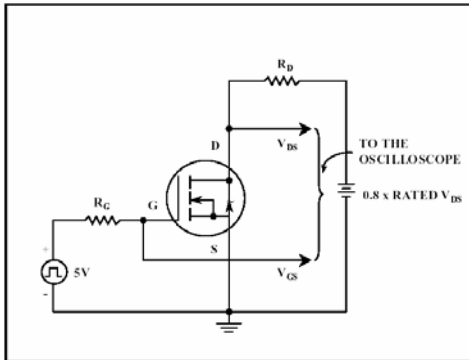

Fig 13. Switching Time Circuit

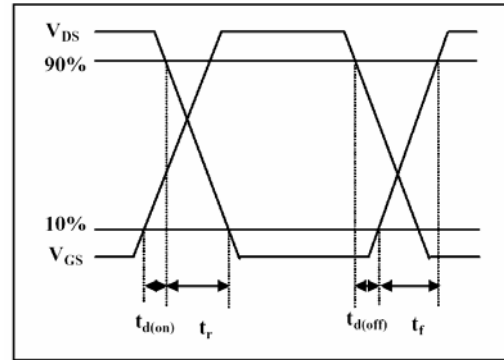

Fig 14. Switching Time Waveform

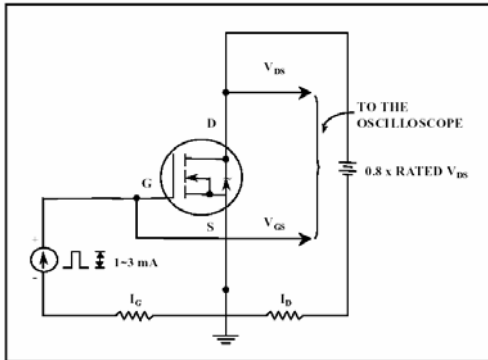

Fig 15. Gate Charge Circuit

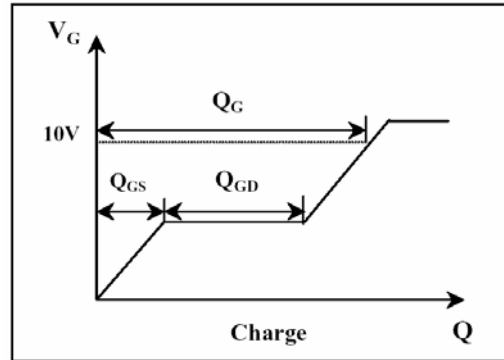
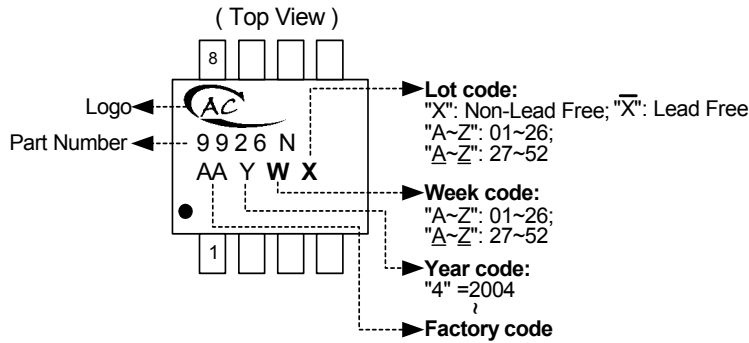

Fig 16. Gate Charge Waveform

## N-Channel Enhancement Mode Power MOSFET

### ■ Marking Information

SOP-8L



### ■ Package Information

Package Type: SOP-8L

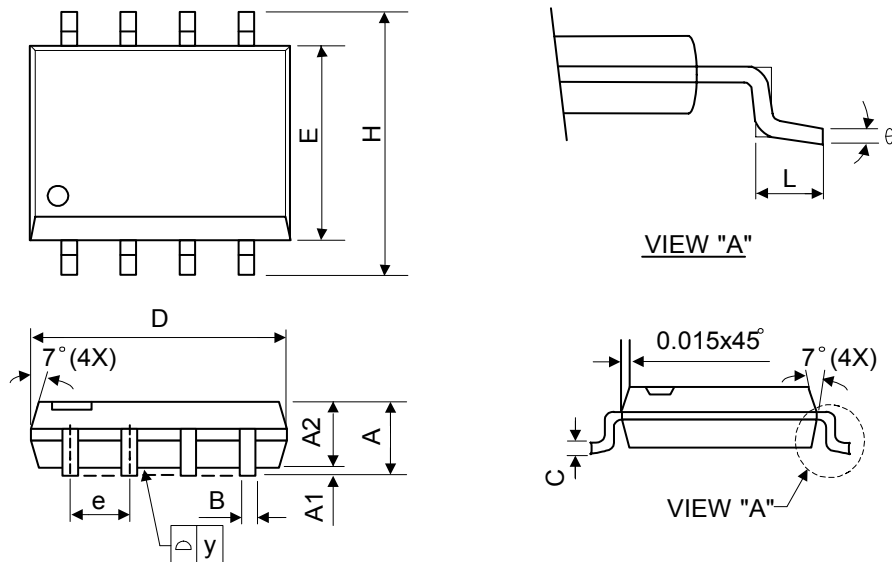

Symbol	Dimensions In Millimeters			Dimensions In Inches		
	Min.	Nom.	Max.	Min.	Nom.	Max.
A	1.40	1.60	1.75	0.055	0.063	0.069
A1	0.10	-	0.25	0.040	-	0.100
A2	1.30	1.45	1.50	0.051	0.057	0.059
B	0.33	0.41	0.51	0.013	0.016	0.020
C	0.19	0.20	0.25	0.0075	0.008	0.010
D	4.80	5.05	5.30	0.189	0.199	0.209
E	3.70	3.90	4.10	0.146	0.154	0.161
e	-	1.27	-	-	0.050	-
H	5.79	5.99	6.20	0.228	0.236	0.244
L	0.38	0.71	1.27	0.015	0.028	0.050
y	-	-	0.10	-	-	0.004
$\theta$	0°	-	8°	0°	-	8°